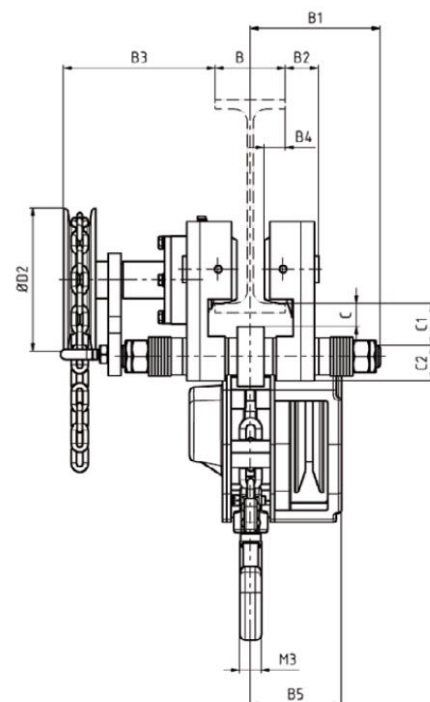
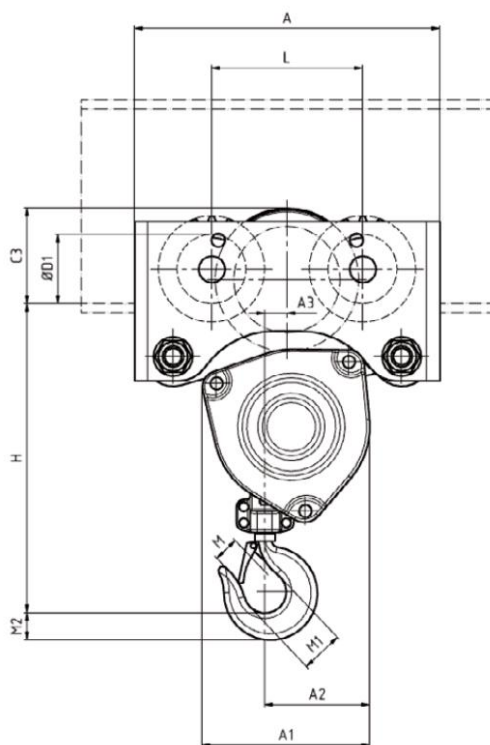

## PALAN-CHARIOT COMBINÉ

5T-6M

Ref : PALAN2993

Caractéristiques techniques :

<b>CAPACITE</b>	5 T
<b>LONGUEUR DE CHAINE</b>	6 M
<b>CHAINE DE CHARGE</b>	10 x 30 mm
<b>NOMBRE DE BRINS</b>	2
<b>LARGEUR DE FER</b>	74 à 192 mm
<b>POIDS</b>	125 Kg

Dimensions (mm) :

A	A1	A2	A3	B1	B2	B3	B4	B5	B6	C	C1	C2	C3	D2	D3	H	L	M	M1	M2	M3
492	206	183	54	190	53	286	28	97	179	33	64	65	162	120	195	600	223	42	59	44	36

[www.blmr.fr](http://www.blmr.fr) - [location@blmr.fr](mailto:location@blmr.fr)