

TREUIL A CABLE PASSANT 0.5T

MINIFOR TR50 - 230V

Ref : **TREUIL1585 (30-60M)**

TREUIL657 (120M)

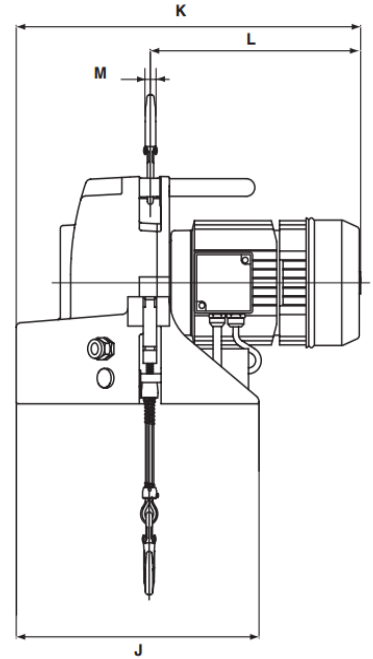
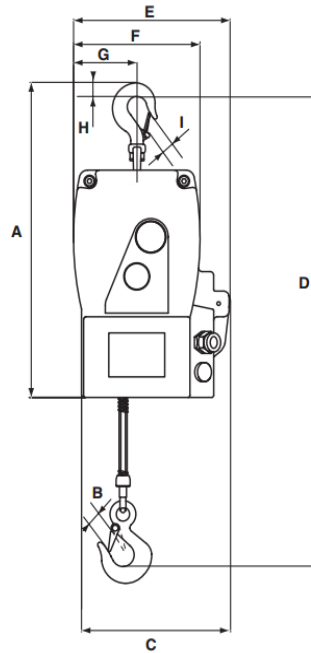

**LONGUEURS DE CABLES DISPONIBLE:
30 - 60 - 120 M
Ø 6.5mm**

CARACTÉRISTIQUES TECHNIQUES :

C.M.U	Tension	Vitesse	Moteur	Dimensions (mm)													Poids
				T	V	m/min	kW	A	B	C	D	E	F	G	H	I	
0,5	230	7	1,1	430	20	212	642	224	181	90	21	21	347	492	302	15	32

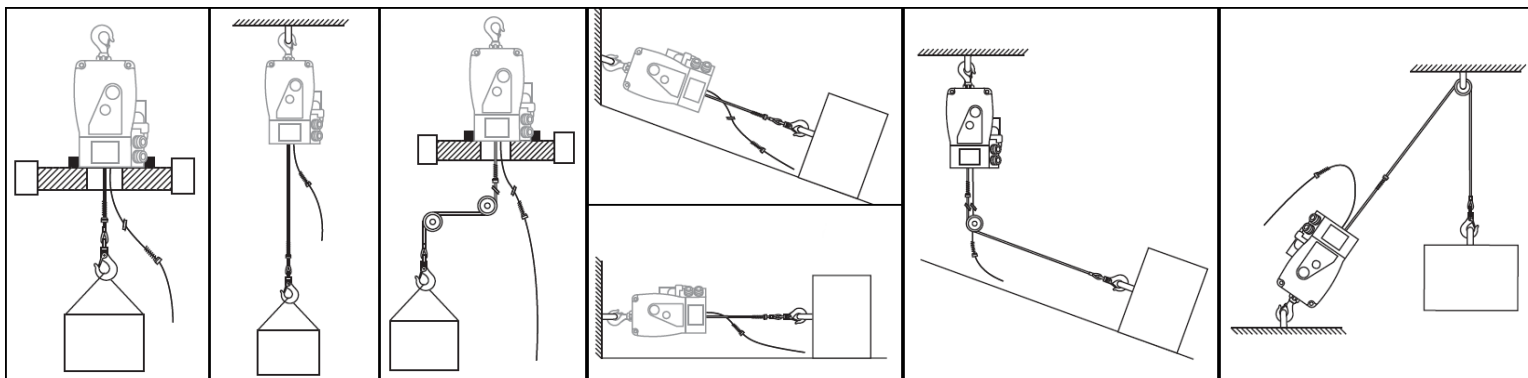

www.blmr.fr - location@blmr.fr

Magasin : 3, Rue Alexis Perroncel - 69100 VILLEURBANNE - TEL: 04.78.89.00.24 - FAX: 04.78.89.45.80